



The Exminster



Gas Stove For Natural Gas and LPG

INSTALLATION, SERVICING AND USER INSTRUCTIONS

This product is for use only in Great Britain and Ireland (GB, IE)

These instructions are to be left with the customer, should be read carefully and kept in a safe place.
They will be necessary when servicing the appliance.

IMPORTANT
THIS APPLIANCE MUST ONLY BE OPENED, INSTALLED AND SERVICED BY A
CORGI REGISTERED ENGINEER

Contents

USER INSTRUCTIONS

Welcome to Yeoman	3
Commissioning Data	4
Guarantee	4
Safety Notes	5
Operating the Stove	5
Remote Control (Manual Operation)	5
Twin Rotary Control with Optional Remote	6
Timer Remote Control	6
Ventilation	7
Arrangement of the Fuel Bed	8

TECHNICAL SPECIFICATIONS

List of Component Parts for Exminster

Gas Stove	11
Dimensions of Stove	11
Technical Information	11
Safety Notes	11

SITE REQUIREMENTS

Flue Requirements	12
Flue Connection	12
Ventilation	12
Locating the Appliance	12

INSTALLATION

Gas Connection	13
Arrangement of the Fuel Bed	13
Operating the Stove	15
Fitting the Canopy	15
Remote Control	15

COMMISSIONING

Completing the Installation	16
Appliance Testing	16
Post Installation Checks	16

SERVICING & FAULT FINDING

Servicing Instructions	17
Trouble Shooting	17
Short Spares List	18
Service Record	19



Welcome to Yeoman

Your new Exminster gas stove is perhaps the most advanced design of modern stoves. Owning such a stove shows appreciation for exceptional quality.

Please read your manual thoroughly, it's purpose is to familiarise you with your stove, and give guidelines for it's installation, operation and maintenance. If after reading this manual you need further information, please do not hesitate to contact your supplier.

IMPORTANT NOTICE

If your stove is installed correctly, it will give you many years of excellent service for which it was designed. This appliance must be installed by a qualified installer, we recommend that you have a CORGI registered engineer to install your stove for you.

WARNING

All types of heating appliance can be potentially dangerous. Correct installation and operating procedures must be observed when fitting this stove. Some parts of your stove are protected on their surface with heat proof paint. When the stove is first used it is normal for it to emit some light smoke, with an unpleasant smell. Though unpleasant, this is not toxic and is produced only whilst the stove paint fully cures. We recommend that you ventilate the room until this disappears.

The fuel effect components in this stove are made from Refractory Ceramic Fibre. Please refer to service instructions on page 17 for safe handling and removal.

USER INSTRUCTIONS

1. COMMISSIONING DATA

This information must be completed and signed by the installation engineer.

Flue correct for appliance	Yes / No
Type of Gas Supply	
Installation engineer	
Signature	
CORGI Reg No.	
Installation date	
Flow Rate is m^3/h	
Meter pressure, all gas appliances on FULL	mbar
Meter pressure, stove on full only	mbar
Length and size of gas supply	
Have controls been upgraded	Yes / No

2. GUARANTEE

All Yeoman stoves are guaranteed for two years against faulty components from the date of purchase, subject to the following conditions:

- That the installation, and any additional work to either the flue or the combustion chamber is carried out by a suitably qualified person (e.g. CORGI registered for a gas stove or HETAS approved for a solid fuel stove).
- That the fireplace (if applicable) and flue installation conform to the relevant building Regulations and British Standards.
- That the correct Yeoman balanced flue components are used on Yeoman Balanced Flue stoves.
- That Yeoman's instructions for installation, servicing and cleaning are followed. In particular, all stoves must be serviced at least annually to remain covered by the guarantee. Also the use of petro-cokes in solid fuel stoves will invalidate this warranty.
- This guarantee does not cover wear and tear items, i.e. items that would normally need to be replaced from time to time. These include ceramic components, thermocouple, pilot assembly and ignition leads in the case of gas stoves and glass, firebricks, grates, log retainers, baffles and rope seal in the case of solid fuel stoves.
- This guarantee does not cover any faults arising from installations that do not conform to the manufacturer's instructions.
- To the extent permitted by law, this guarantee is limited to the cost of the replacement of the faulty part or the free of charge replacement of that part; and does not cover any further consequential losses arising.

- The completion and return of Stovax's warranty registration card, which is supplied with your stove.

None of the above restrict your statutory rights.

For your records and to assist us in any guarantee claim please make a note of the Stockist from whom purchased:

Name _____
Address _____

Tel _____

Date Installed _____

Installed by: _____

Address _____

Tel _____

Model Type (see data badge) _____

Serial No. (see data badge) _____

We are pleased that you have chosen a Yeoman stove, which we hope will give you many years of pleasure. Please ensure that you read through your manual thoroughly, as its purpose is to familiarise you with your stove, and give guidelines for its installation, operation and maintenance. If after reading this manual you need further information then please contact your supplier.

USER INSTRUCTIONS

3. SAFETY NOTES

The Exminster gas stove is designed to be used with either Natural Gas or LPG, however each individual appliance is only capable of using the gas specified on the data plate. It is important to note that once a gas type has been specified, the stove cannot be used with any other gas. The type of gas the stove is capable of burning is stated on the data plate located on the front of the stove, by the control knob, check that the appliance has been correctly supplied.

Installation of your Yeoman Stove must comply with current building regulations. Yeoman Stoves therefore recommend that a CORGI engineer be employed for this task. The engineer will provide you with information about the safety limits of the installation and should fix a notice plate in a place where it can be readily seen, eg: next to the electricity meter.

This appliance must never be operated with the doors open or removed, or if the glass is broken. This appliance is designed as an efficient heating device and consequently all body parts of the stove become very hot in use. Except for the control knob and control access door, which are designed to stay cool, all other parts are working surfaces and should not be touched.

The glass and door on this appliance acts as a fireguard conforming to BS:1945 – 1971 and satisfies the Heating Appliance (Fireguards) regulations 1991. No part of the glass or door should be permanently removed. It does not give full protection for young children or the infirm, extra protection conforming to BS 6539 or BS 6778 should be considered for these conditions.

Bearing in mind that the heat given off by this appliance may affect articles placed close to it, curtains should not be placed within 300mm.

The appliance is not designed as a dryer. It is not therefore recommended that the appliance be used in such a manner. Do not place any articles within 300mm of the stove as this may result in damage to the articles.

4. OPERATING THE STOVE

IT IS VERY IMPORTANT TO READ THESE INSTRUCTIONS THOROUGHLY BEFORE LIGHTING THE STOVE.

The stove will produce an odour and/or smoke for the first few hours of use when new. Please ventilate the room when first lighting from new.

This appliance incorporates an O.D.S (Oxygen Depletion Sensor) in the pilot assembly on the burner, which is non-adjustable.

Its purpose is to monitor the air condition in the room and cut of the gas to the appliance before the air condition in the room reaches any harmful levels.

The O.D.S must only be replaced with the manufacturers original parts.

The controls for the stove are located behind the access door positioned under the front of the stove. To access, open the door by pulling from the right hand side.

The Exminster operates with a permanent pilot light. The pilot light is located in the centre of the burner and is visible through a cut-out in the ceramic matrix. If the Flame Supervision Device Actuating Flame (the Pilot Light) is extinguished either by intention or not, no attempt should be made to re-light until 3 minutes have elapsed.

Important: Immediately after lighting, the stove must be left on HIGH for ten minutes in order to warm up the flue.

4.1. REMOTE CONTROL (MANUAL OPERATION)

1a) Igniting the Pilot Light

1. Turn the Left hand knob slightly anti-clockwise towards the ignition position until reaching stop, depress and hold for five seconds (only pilot gas flows). See Fig. 1.
2. Whilst still depressed, turn further in a anti-clockwise direction to activate the piezo. If the pilot does not light, steps 1 and 2 can be repeated immediately.
3. Continue to keep the knob depressed for a further 10 seconds, after the pilot has been lit.
4. Upon releasing the knob, the permanent pilot will remain lit, if not return to 1.

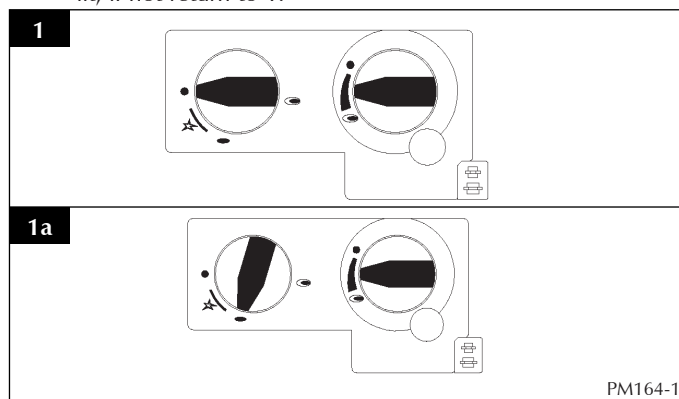

b) Running the stove at high output

1. Ignite permanent pilot as shown in Fig.1a.
2. Turn the left-hand control knob anti-clockwise to the setting, which shows the larger flame. See Fig. 2.
3. Turn the right-hand control knob anti-clockwise to the highest setting (large flame).
4. The stove is now burning at it's highest operating output.

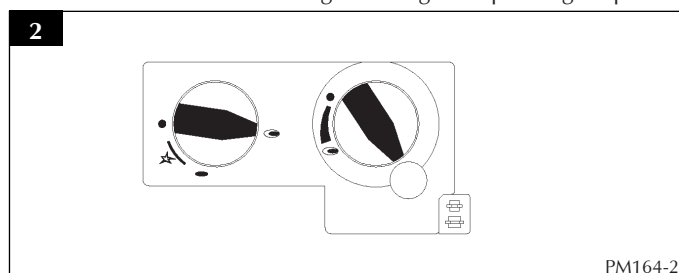

USER INSTRUCTIONS

c) Running the stove at low setting

1. Ignite permanent pilot and run stove at "HIGH" setting for a minimum of 10 minutes as shown in Fig. 2.
2. With the right-hand control knob at the highest setting, rotate in a clock-wise direction to the lowest setting (filled circle). See Fig. 3.

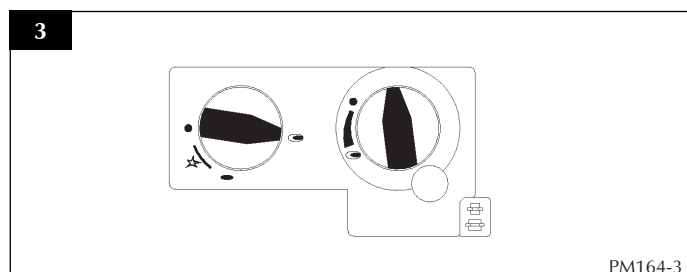

d) Extinguishing the stove back to permanent pilot setting

1. From any heat setting, turn the left-hand knob in a clockwise direction to the "PILOT" position (a smaller flame is shown). See Fig. 4

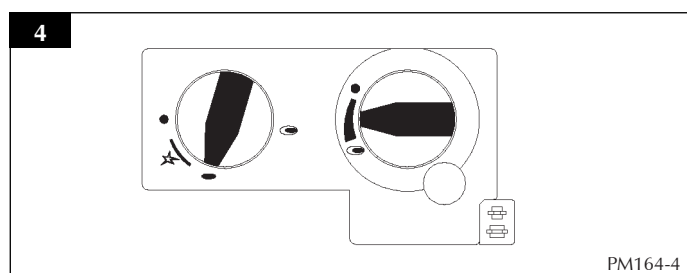

e) Extinguishing the stove fully

1. From any heat setting, turn to "PILOT" as in Fig 4.
2. Depress the same knob slightly and turn clockwise to "OFF" position (filled circle). See Fig. 5.

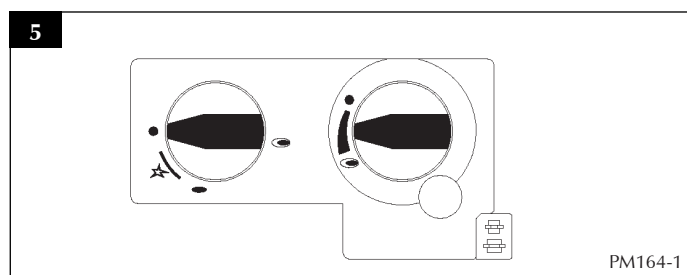

5. TWIN ROTARY CONTROL WITH OPTIONAL REMOTE

Light the pilot as described in section 4.1a. Turn left hand control anti-clockwise until it is on the large flame setting. You are now able to use the remote control. To increase the flame, the top button should be pressed. Pressing the lower button on the handset will reduce the flame. It is also possible to turn the main burner all the way down so that it is effectively off, leaving only the pilot ignited.

5.1. TIMER REMOTE CONTROL

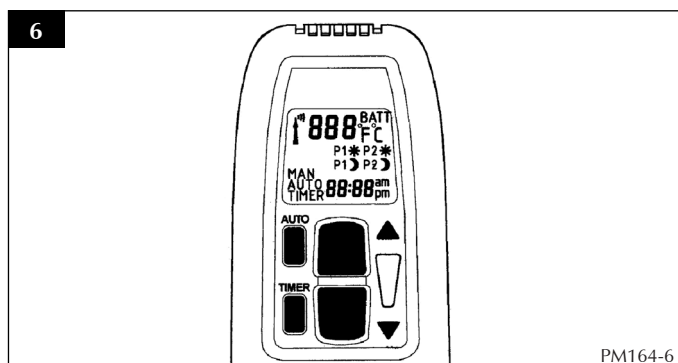

TRANSMITTER FUNCTION

SET THE DISPLAY

After connecting the battery or by simultaneously pressing AUTO and TIMER, the display flashes. You are in set mode. From set mode, press AUTO to switch from Degrees F (and 12 hour clock) to degree C (and 24 hour clock) or vice versa.

The display will automatically return to manual mode after some time, but you may immediately return to manual by depressing the TIMER button.

SET THE CURRENT TIME

After connecting the battery or by simultaneously pressing AUTO and TIMER, the display flashes. You are in set mode. From set mode, press ▲ to set the hour and ▼ set the minute.

Wait or press TIMER to return to "manual" mode.

PROGRAMMING THE DESIRED SET TEMPERATURE

Press AUTO until the display flashes. Press ▲ or ▼ to set the desired temperature. Wait or press AUTO to switch to automatic mode. A sensor in the transmitter measures room temperature. The controller compares the room temperature with the set temperature and sends a signal to the receiver to turn the gas valve motor, which adjusts the flame height accordingly.

PROGRAMMING THE TIMER

Press TIMER until P1* flashes (period 1, heating cycle on). Set the time for the beginning of the first heating period by pressing ▲ for hour and ▼ for minute. Press TIMER again; P1) appears.

Set the time for the end of the first heating period.)

USER INSTRUCTIONS

Press **TIMER** again to set the second heating period **P2*** heat on and **P2** (heat off)

Store both heating periods by pressing **TIMER** again.

If only one period is desired, program the same time for **P2*** and **P 2.**)

MANUAL MOD (MAN IN DISPLAY) FOR MANUAL FLAME HEIGHT ADJUSTMENT

Press **▲** to turn on the fire (main burner) or to increase flame height. Press **▼** to decrease flame or to turn down to pilot.

To incrementally increase or decrease the flame height lightly tap either the **▲** or **▼** button.

The "send" symbol appears in the upper left corner of the display when either button is depressed.

The LED of the receiver flashes when the larger knob of the valve reaches its end stops.

AUTOMATIC MODE (AUTO IN DISPLAY) FOR TEMPERATURE CONTROL

Briefly press **AUTO**. The set temperature will appear briefly before the display reverts to the room temperature.

TIMER MODE (TIMER IN DISPLAY)

During heating periods **P1*** and **P2***, the temperature is controlled in the same manner as in automatic mode. When the timer programme turns to **)** (heating cycle off), the motor will turn the valve to the pilot and there is no temperature control. This minimises battery consumption. You may press **AUTO** to verify the set-temperature and then press **TIMER** to return to timer mode

You may press either the **▲** or **▼** button from any mode for manual override.

To prolong battery life, we recommend switching the transmitter to manual mode and turning the fire to pilot with the **▼** button before turning the appliance off. If the transmitter is left in automatic or timer mode, the batteries will continue to be used when the appliance is off.

CHANGING THE BATTERY

If 'BATT' appears in upper right hand corner of the display or if the LED of the receiver becomes faint, please change the battery from the transmitter or receiver. If the batteries lose power, the flame height can be adjusted by manually turning the larger knob.

NOTE

Please note, the placement of the transmitter (temperature sensor) is important to assure proper temperature regulation. Generally, a more constant temperature will be assured, if the transmitter is not too far from the gas appliance. Before switching to **AUTO** or **TIMER** mode, press either button **▲** or **▼** to verify reception (when the send symbol appears in the transmitter display, the receiver's LED must illuminate) For the **AUTO** or **TIMER** mode to function

correctly, the transmitter must remain within range of the receiver. The transmitter should not be used in very close proximity to the receiver (less than 1m/3ft) as this could, in very rare cases, produce an electronic switching error. This error could block the motor when the larger knob reaches the end points of its turning radius. The knob must then be turned manually to free the blockage.

The temperature is controlled by activating the motor for a specific length of time to adjust the appropriate flame height. This time is calculated by the transmitter and depends on variables such as room size, heater capacity, battery power etc., Therefore, a few cycles are necessary before an optimum is achieved. If a low flame is sufficient to provide enough warmth to the room, then the appliance will cycle between low fire and off. This allows longer periods with the flame on and provides a more uniform room temperature.

It is recommended to turn the combination control either to the off or pilot position if the appliance is left unattended for longer periods (eg. Holidays), so that it cannot receive commands from the remote transmitter. Exercise caution when leaving the appliance unattended, in exceptional cases sound waves from sources other than the transmitter can cause changes in flame height adjustment.

6. VENTILATION

The Exminster gas stove is rated at less than 7 kW; it therefore does not normally require additional ventilation in the room to conform to BS 5871 pt.2. However it is important that adequate air for complete combustion is available, and also if other gas appliances or extractor fans are fitted in the same room or adjacent area, then it will be necessary to refer to BS 6714 and BS 5440: pt.2. to ascertain the additional ventilation requirements.

USER INSTRUCTIONS

7. ARRANGING THE LAYOUT OF THE COALS

Use only the ceramic coals supplied with this appliance.
Lay the coals as shown on the following pages only.

Replacement coals, ceramic and mat are available from your dealer.

The parts required for the fuel effect layout are listed below:

1	Front Matrix left
1	Front Matrix right
1	Rear Matrix left
1	Rear Matrix right
1	Top centre Matrix
5	Small Ceramic Coals
1	Large Ceramic Coal
1	Ceramic Mat

See Fig. 6 to identify components.

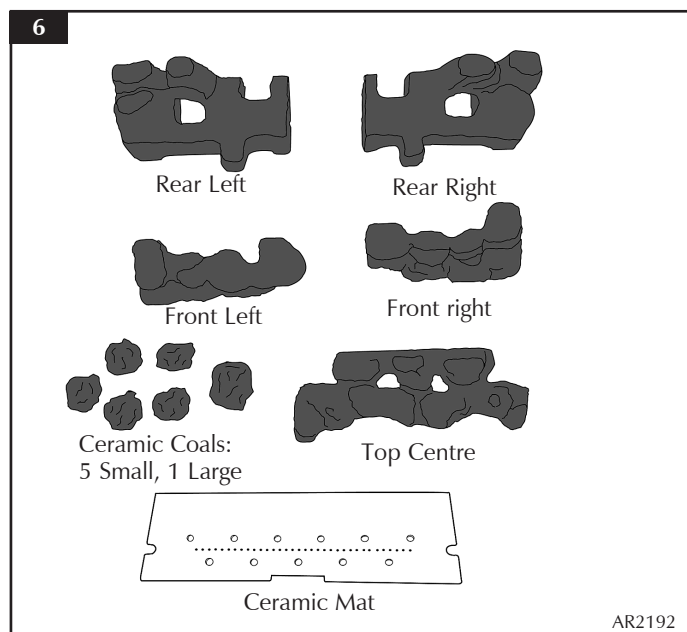

8. PROCEDURE FOR ARRANGEMENT

Ensure that the Pilot Assembly remains unobstructed when arranging the matrix and coals.

The coals become very hot when the stove is operating. Take care adjusting coals after the appliance has been lit, Yeoman Stoves accept no responsibility for any injury sustained whilst handling hot ceramics.

The door must be open to access the coals:
To achieve this:

- Unscrew the cast handle to reveal an M6 nut
- Unscrew the nut, and door will open

STAGE 1

Lay the Ceramic Mat on top of the Burner as shown in Fig. 7. Make sure that no holes, including the small cross lighting holes are blocked. The pilot assembly must not be obstructed.

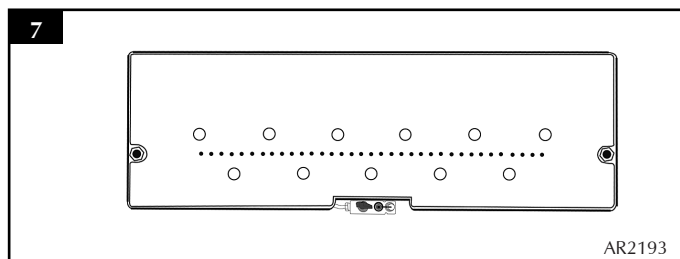

STAGE 2

Place the Rear Left & Right Matrices on top of the mat and burner as shown in Fig. 8.

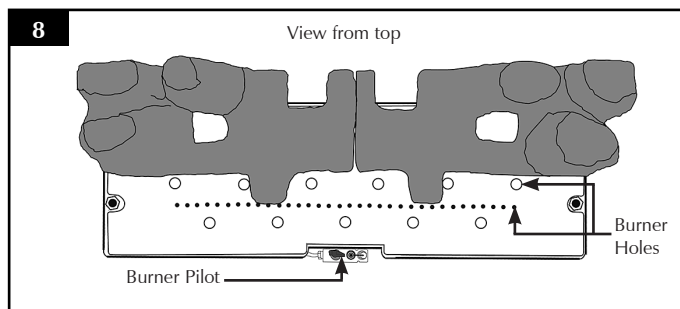

The matrices should be placed with the rear underside slot locating over the back of the burner for **Nat Gas**, or the front slot located over the back of the burner for **L.P.G** Fig 9.

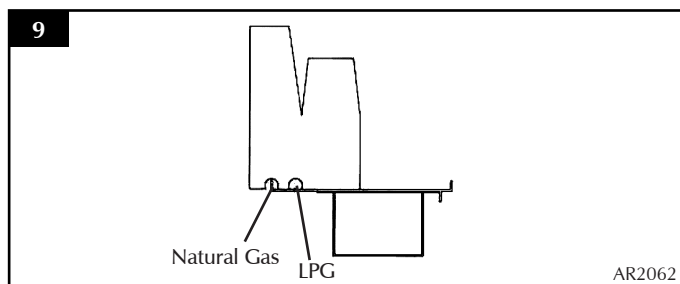

STAGE 3

Place the Front Left & Right Matrices as shown in Fig. 10. The lugs on the under side locate against the front edge of the burner tray.

Position the two matrices so that the burner ports are not obstructed. Due to the shape they may touch in the middle or a small gap may be visible. This will be above the pilot head, but not central.

Note: The burner holes must still be visible after the front matrices are in position.

USER INSTRUCTIONS

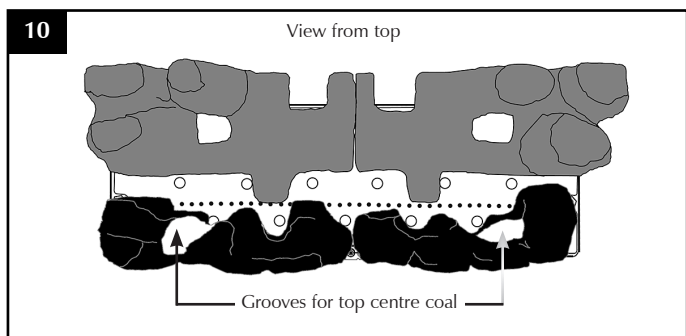

STAGE 4
Position the Top centre Matrix as shown in Fig.11.

Note: On Natural Gas appliances the Top Matrix is pulled forward to locate and touch the grooves in the front matrices. For LPG it should be positioned back from the front matrices supported on the two protruding extensions.

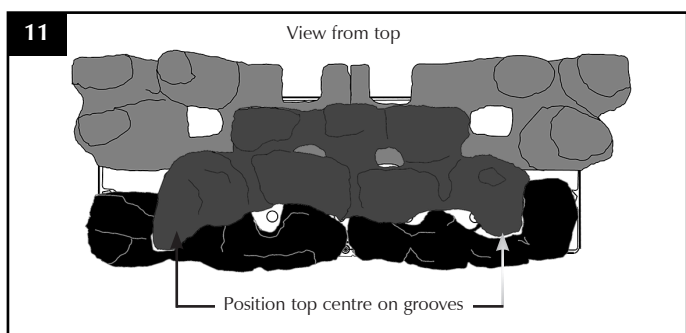

Note: There is a larger air space between the front and rear matrix for LPG.

STAGE 5
Place the 5 small Ceramic Coals across the front and the 1 larger coal in the central position as shown in Fig. 12. Locate the coals into the cutouts in the Matrices.

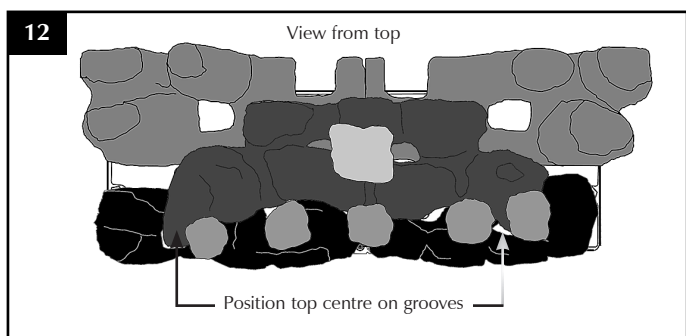

STAGE 6
Arrangement complete.

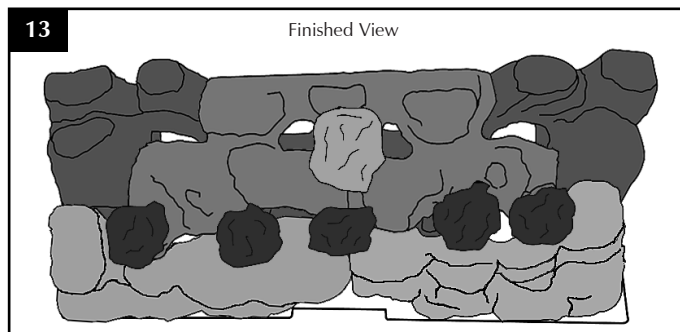

STAGE 7
Close the door:
This is the reverse of the opening procedure.

9. ARRANGING THE LAYOUT OF THE LOGS

Only the ceramic Logs supplied with this appliance are to be used. The Logs must be laid only as shown on the following pages.

Replacement logs and ceramic mat are available from your dealer, but should only be installed by a CORGI registered engineer.

The parts required for the log layout are listed below:-

1	Ceramic Mat
1	Bag of Embers
1	Left Rear Log
1	Right Rear Log
1	Large Centre Log
1	Centre Front Log

STAGE 1
Place the large centre log at the back of the burner as shown in Fig. 14.

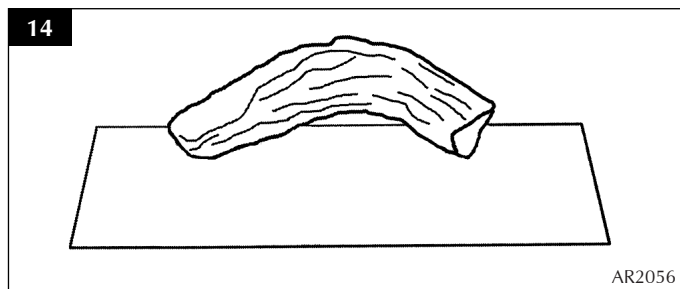

STAGE 2
Lay the right rear log as shown in Fig 15.

USER INSTRUCTIONS

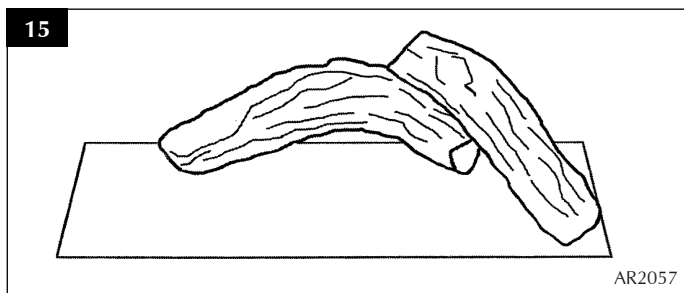

AR2057

STAGE 3

Lay the left rear log as shown in Fig. 16.

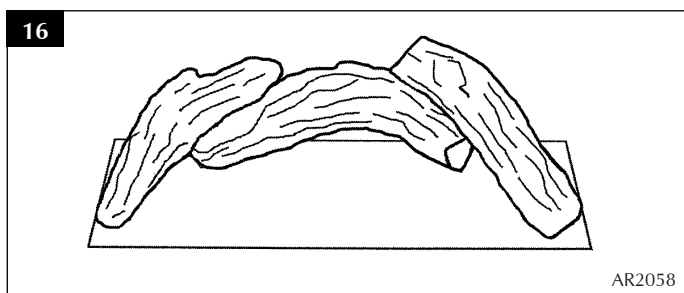

AR2058

STAGE 4

Lay the granules on top of the white ceramic mat, between the logs, as shown in Fig 17, making sure the pilot is not covered.

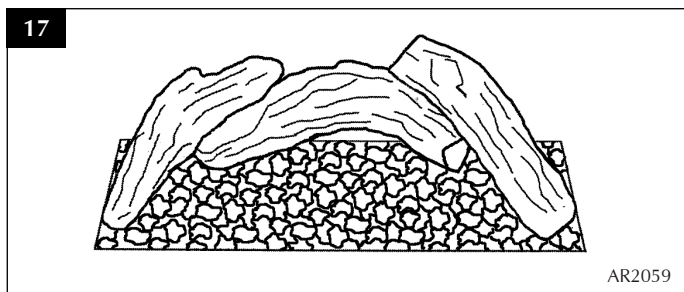

AR2059

STAGE 5A (LPG ONLY)

For LPG appliances place the front centre log as shown in fig. 18.

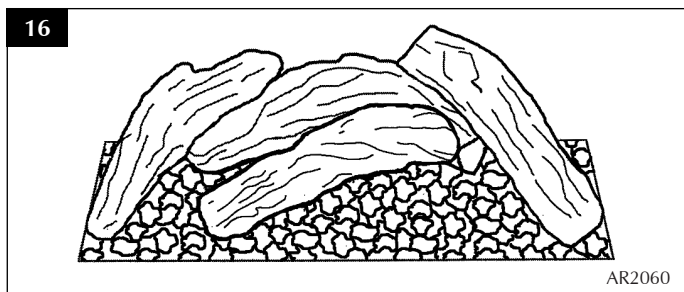

AR2060

STAGE 5B (NATURAL GAS ONLY)

For natural gas appliances place the front centre log as shown in fig. 17.

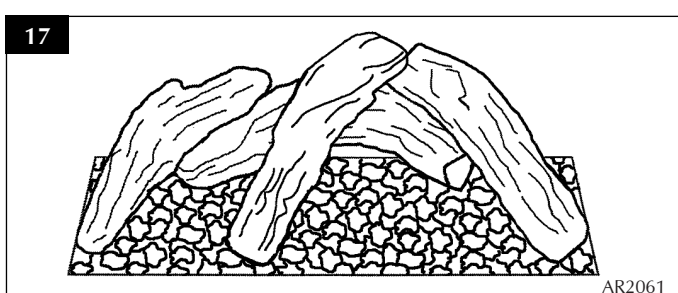

AR2061

1. LIST OF COMPONENT PARTS FOR THE EXMINISTER GAS STOVE

1 No.	Stove body complete with burner		
Coals		Logs	
1	Front Matrix left	1	Rear Centre Log
1	Front Matrix right	1	Left Rear log
1	Rear Matrix left	1	Right Rear log
1	Rear Matrix right	1	Centre Front log
1	Top centre Matrix	1	Bag of embers
5	Small Ceramic Coals		
1	Large Ceramic Coal		
1	Ceramic mat		

1 No.	Flue fixing kit comprising of:
1	125mm Bolt on flue Connector
1	Flue Blanking plate
2	Flue gaskets
6	M6 x 20 set screw
3	M6 standard washers
1	Instruction Manual

Prior to commencement of installation of the appliance, the flat top or canopy which has been fitted for transportation must be removed.

This is achieved by opening the appliance door(s) and then removing the two M8 nuts and washers located in the top of the stove, on the underside of the flange.

TECHNICAL SPECIFICATIONS

2. DIMENSIONS OF THE STOVE

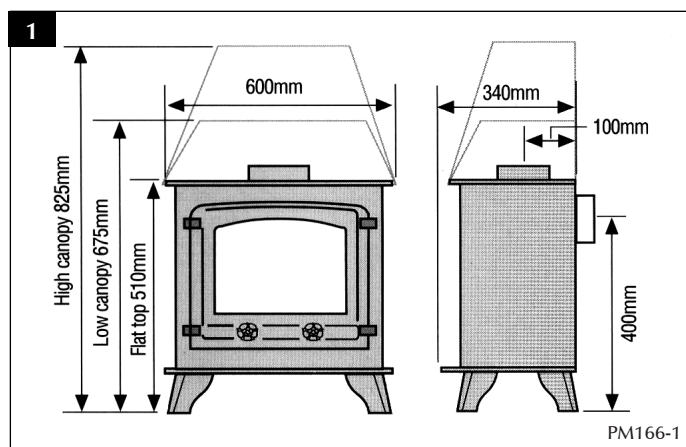

3. TECHNICAL INFORMATION

Inlet pipe connection:	8mm compression.
Chimney Requirements:	Class I or Class II
Flue fitting:	5" diameter Top or Rear outlet
Flue monitor:	Oxygen Depletion Sensor (ODS)
Stove control:	Front mounted variable rotary gas Control With integrated Piezo ignition, Permanent pilot facility, Flame failure device and flue monitor. OR as above with Remote Control Option Receiver - 4x AA (Alkaline only) Transmitter - (Alkaline only), 1 x PP3.
Battery type (Remote version)	
NOx level:	Class 5 (i.e. below 100 mg/kWh)

	I ² H/G20 Natural Gas	I ³ P/G31 Propane	13+/G30 Butane
Heat Input	6.1 kW	5.7 kW	6.0 kW
Supply Pressure	20 mbar	37 mbar	29 mbar
Gas Rate	0.58 ³ /h	0.21 m ³ /h	0.17 ³ /h
Injector	400	160	160

4. SAFETY NOTES

This appliance incorporates an O.D.S (Oxygen Depletion Sensor) in the pilot assembly on the burner, which is non-adjustable. The ODS shall not be adjusted by the installer or put out of operation.

Its purpose is to monitor the air condition in the room and cut of the gas to the appliance before the air condition in the room reaches any harmful levels.

The O.D.S or any of its parts must only be replaced with genuine Yeoman parts.

1. FLUE REQUIREMENTS

The flue which the appliance is to be attached must conform to BS 5440 1990:pt.1. Before the appliance is installed, the flue system or chimney must be inspected and passed as suitable.

This stove is suitable for installation onto either flexible or fabricated steel flue systems. The minimum effective height of the flue must be three metres measured from the hearth to the termination of the flue. If the flue has any sections that are not vertical, the height should be increased in line with BS 5440 pt.1. Prior to installation, the installer should ensure that the flue is free from obstruction, ideally should be swept and subsequently smoke tested. Ensure that any dampers are fixed in a permanently open position. The appliance has been designed with a built in draught divert, and as such no further draught divert need be fitted to the flue system.

NOTE: If it is intended to fit the stove into an existing brick built chimney without a closure plate, a 5" (127mm) liner must be used. Larger lined flues may work, but in some instances could cause cold start flue problems resulting in nuisance shutdown. Lined flues above 7" (175mm) are not recommended.

Prior to installation a smoke test must be carried out to ascertain that there is sufficient draught in the flue for safe operation of the stove.

2. FLUE CONNECTION

The Exminster stove may be installed as either top or rear flue, and as such comes with all relevant parts to enable connection of flue to either flue system.

If the appliance is to be installed as a Top Flue, place 1 of the flue gaskets on the top flue position. Using 3 M6 set screws and M6 washers attach the flue connector and tighten up to ensure that the gasket is fully sealing and is airtight. Repeat this operation on the back plate with the flue blanking plate (with 3 holes drilled) and 3 M6 set screws; once again ensuring that the gasket enforces a good seal and is air tight. This will leave the Flat Top Infill (no holes); this part is redundant and may be disposed of.

If the stove is to be fitted as a rear flue, the same procedure as above should be followed but with the Flue Connector and Flue Blanking Plate reversed. If fitted as Rear Flue then the Flat Top Infill will sit on top of the screws holding the Flue Blank and will then sit flush with the Top plate.

It is recommended that a minimum height of 610mm from the stove should be established before any significant changes in direction of the flue. Horizontal or negative gradients in the flue pipe are to be avoided.

The flue system may now be connected to the stove; this should be sealed using a fire resistant sealant.

SITE REQUIREMENTS

Please note that all flue systems should be installed in accordance with the flue manufactures recommendations and BS5871:pt.1.

When installing the flue in properties of timber framed construction, the regulations (BS 5440:Part 1:1990) must be adhered to.

3. VENTILATION

The Exminster gas stove is rated at less than 7 kW; it therefore does not normally require additional ventilation in the room to conform to BS 5871 pt.2. However it is important that adequate air for complete combustion is available, and also if other gas appliances or extractor fans are fitted in the same room or adjacent area, then it will be necessary to refer to BS 6714 and BS 5440: pt.2. to ascertain the additional ventilation requirements.

4. LOCATING THE APPLIANCE

The appliance must stand on a fireproof hearth, which is manufactured of a non-combustible material with a minimum thickness of 12mm and must extend to at least 100mm past the lip of the stove.

The appliance must not be fitted against a rear wall constructed from a combustible material. A minimum gap of 280mm should be given all round the stove before combustible materials may be used in the wall construction. There must be a minimum of 75mm clearance behind the stove measured from the rear edge of the draft diverter to any non-combustible surface.

If the appliance is located in an opening, there must be a minimum of 150mm each side of the appliance and 75mm to the rear measured from the rear edge of the draft diverter.

A combustible shelf may be fitted over the appliance, if in the case of a 150mm or less deep shelf, there is at least 280mm clearance above the top of the stove. The shelf depth may increase at the same rate as the increase in clearance; i.e. a shelf depth of 200mm would require a clearance of 330mm.

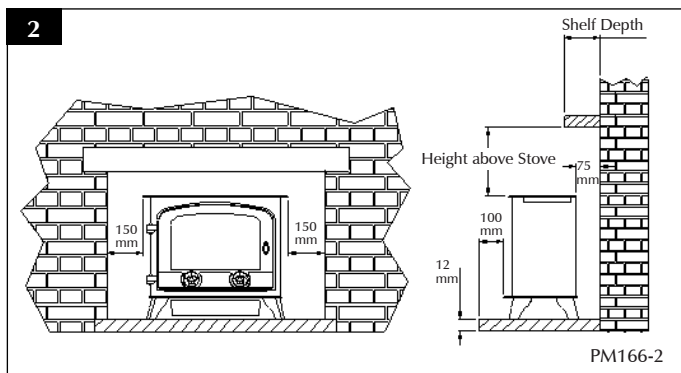

1. GAS CONNECTION

Before installation, ensure that the local distribution conditions (identification of the type of gas and supply pressure) and the adjustment of the appliance are compatible.

It is important to ensure that all pipe work installed is fitted in accordance with BS6891 and is capable of supplying sufficient gas flow and pressure to meet the minimum pressures quoted in page 11 of this manual. A minimum pipe size of 15mm should be used for the gas supply to within 1 metre of the appliance. 8mm pipe may only be used for the final connection to the stove, or within 1 metre of the appliance. An 8mm nut and olive is supplied with the stove for the final pipe joint. A length of formed pipe is supplied with the stove and test point elbow (with isolation valve), please fit as desired and check soundness before final positioning of the appliance.

Do not make any connections to the appliance until all supply pipes have been purged to expel any dust or debris. Failure to do this may result in a blocked injector or tap and will invalidate the guarantee.

Although a gas soundness test is made on all appliances before they leave the factory, the appliance must be tested for soundness before operating the stove. This is to ensure that the burner has not been damaged in transit.

The Exminster gas stove is designed to be used with either Natural Gas or LPG, however each individual appliance is only capable of using the gas specified at the time of purchase. It is important to note that once a gas type has been specified, the stove cannot use any other gas. The type of gas the stove is capable of burning is stated on the data plate located on the front of the stove, by the control knob. Check that the appliance has been correctly supplied.

INSTALLATION INSTRUCTIONS

2. ARRANGING THE LAYOUT OF THE COALS

Use only the ceramic coals supplied with this appliance.
Lay the coals as shown on the following pages only.

Replacement coals, ceramic and mat are available from your dealer.

The parts required for the fuel effect layout are listed below:

1	Front Matrix left
1	Front Matrix right
1	Rear Matrix left
1	Rear Matrix right
1	Top centre Matrix
5	Small Ceramic Coals
1	Large Ceramic Coal
1	Ceramic Mat

See Fig. 3 to identify components.

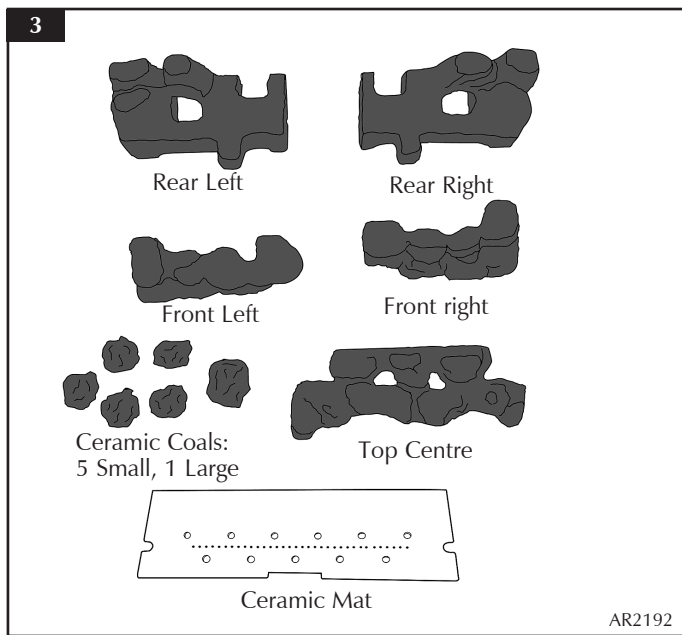

3. PROCEDURE FOR ARRANGEMENT

Ensure that the Pilot Assembly remains unobstructed when arranging the matrix and coals.

The coals become very hot when the stove is operating. Take care adjusting coals after the appliance has been lit, Yeoman Stoves accept no responsibility for any injury sustained whilst handling hot ceramics.

The door must be open to access the coals:

To achieve this:

- Unscrew the cast handle to reveal an M6 nut
- Unscrew the nut, and door will open

STAGE 1

Lay the Ceramic Mat on top of the Burner as shown in Fig. 4. Make sure that no holes, including the small cross lighting holes are blocked. The pilot assembly must not be obstructed.

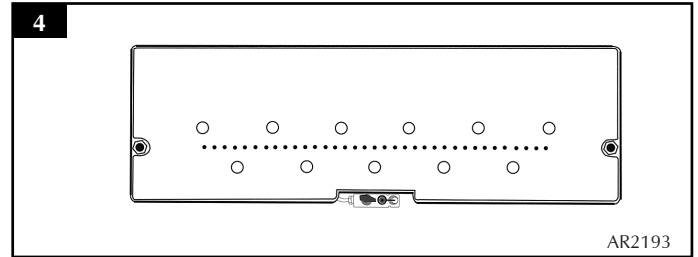

STAGE 2

Place the Rear Left & Right Matrices on top of the mat and burner as shown in Fig. 5.

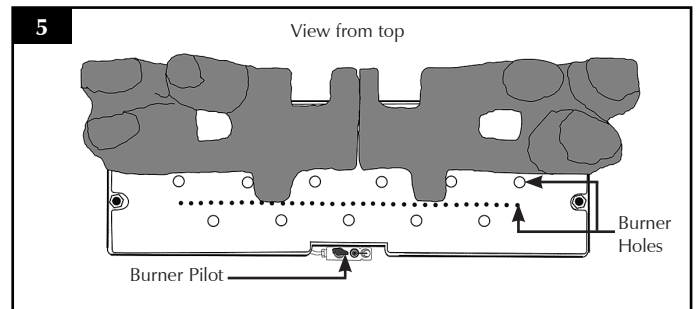

The matrices should be placed with the rear underside slot locating over the back of the burner for **Nat Gas**, or the front slot located over the back of the burner for **L.P.G** Fig 6.

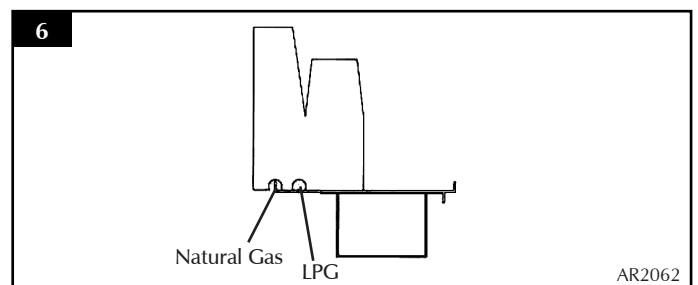

STAGE 3

Place the Front Left & Right Matrices as shown in Fig. 10. The lugs on the under side locate against the front edge of the burner tray. Position the two matrices so that the burner ports are not obstructed. Due to the shape they may touch in the middle or a small gap may be visible. This will be above the pilot head, but not central.

Note: The burner holes must still be visible after the front matrices are in position.

INSTALLATION INSTRUCTIONS

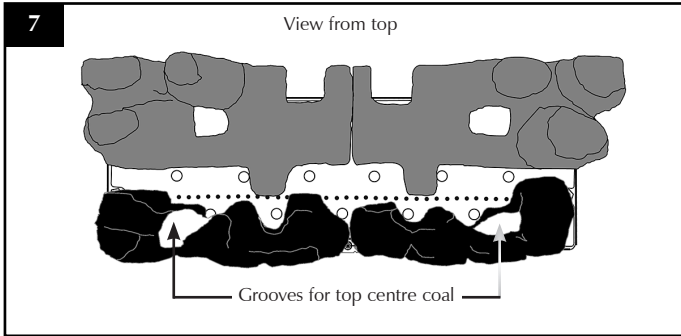

STAGE 4

Position the Top centre Matrix as shown in Fig.8.

Note: On Natural Gas appliances the Top Matrix is pulled forward to locate and touch the grooves in the front matrices. For LPG it should be positioned back from the front matrices supported on the two protruding extensions.

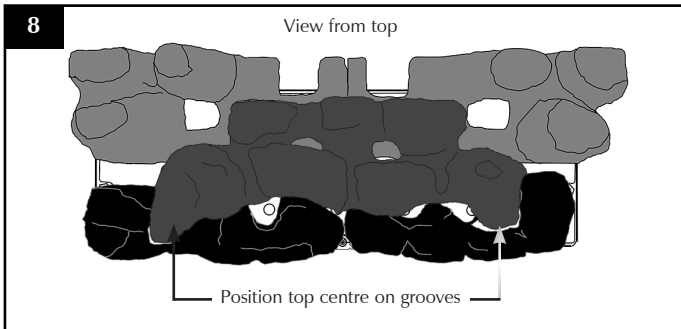

Note: There is a larger air space between the front and rear matrix for LPG.

STAGE 5

Place the 5 small Ceramic Coals across the front and the 1 larger coal in the central position as shown in Fig. 79. Locate the coals into the cutouts in the Matrices.

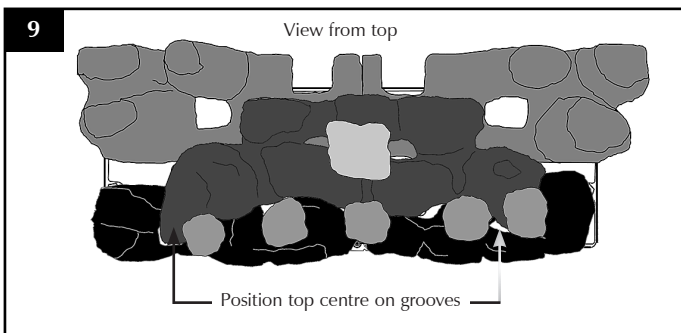

STAGE 6

Arrangement complete.

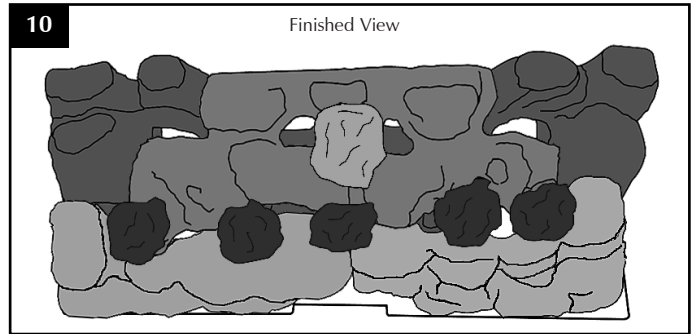

STAGE 7

Close the door:

This is the reverse of the opening procedure.

4. ARRANGING THE LAYOUT OF THE LOGS

Only the ceramic Logs supplied with this appliance are to be used. The Logs must be laid only as shown on the following pages.

Replacement logs and ceramic mat are available from your dealer, but should only be installed by a CORGI registered engineer.

The parts required for the log layout are listed below:-

1	Ceramic Mat
1	Bag of Embers
1	Left Rear Log
1	Right Rear Log
1	Large Centre Log
1	Centre Front Log

STAGE 1

Place the large centre log at the back of the burner as shown in Fig. 11.

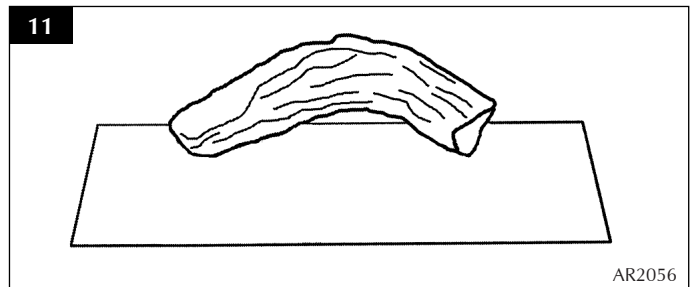

STAGE 2

Lay the right rear log as shown in Fig 12.

INSTALLATION INSTRUCTIONS

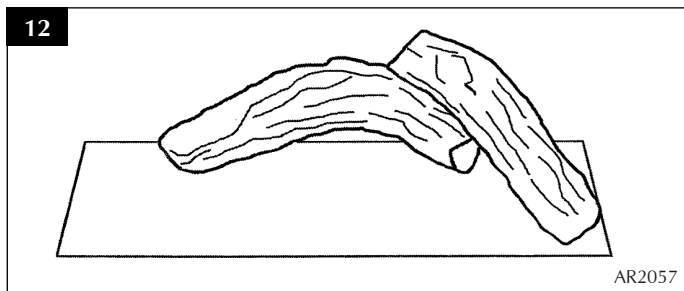

STAGE 3

Lay the left rear log as shown in Fig. 13.

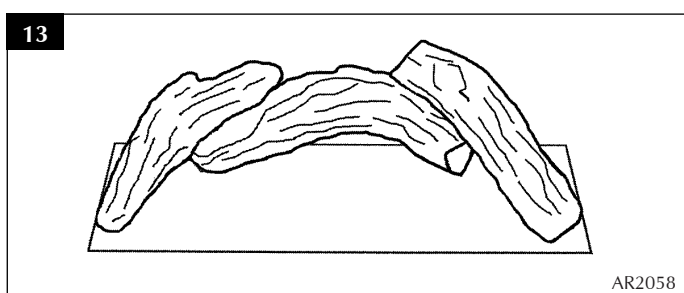

STAGE 4

Lay the granules on top of the white ceramic mat, between the logs, as shown in Fig 14, making sure the pilot is not covered.

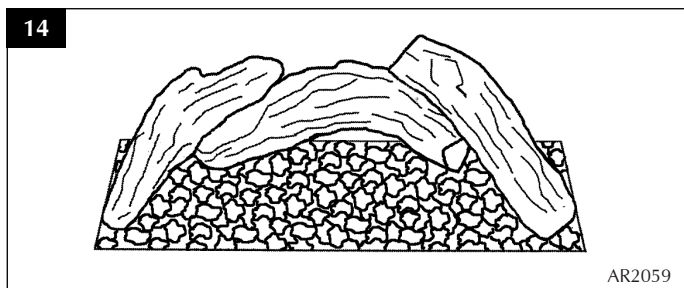

STAGE 5A (LPG ONLY)

For LPG appliances place the front centre log as shown in fig. 15a.

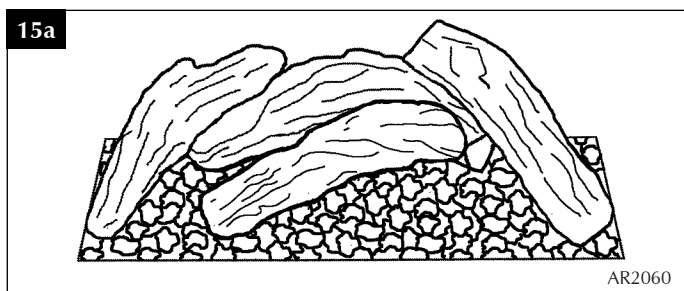

STAGE 5B (NATURAL GAS ONLY)

For natural gas appliances place the front centre log as shown in fig. 15b.

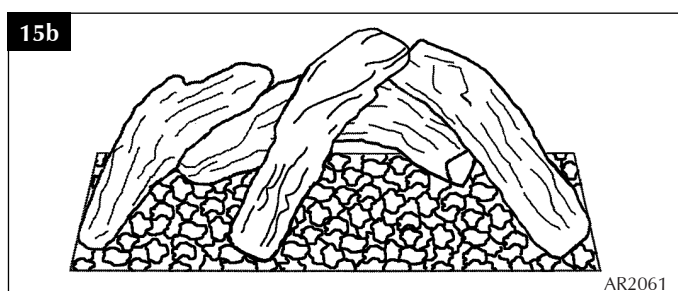

5. OPERATING THE STOVE

See User Section

6. FITTING THE CANOPY

All Exminster gas stoves are supplied with bolt on top options. The tops are fixed to the stove body using two M8 nuts and M8 penny washers.

First place the top (either Flat Top or Canopy) on to the body, locating the studs on the underside of the canopy through the holes in the top of the stove. Apply the washer and nut from the inside top of the stove, whilst the doors are still open, to fix the top and seal the appliance.

It is important to check that these nuts are tight and that no spillage can occur, a smear of fire sealing compound should be used on the washer and nut, to guarantee the seal. The stove must be checked for leakage as part of the commissioning by the installer.

7. CONNECTING THE REMOTE CONTROL

Refer to installation instructions supplied with remote control unit for fitting motor and receiver.

This stove requires no external electrical power to operate.

The receiver unit can be hidden under or behind the appliance, ensure that the receiver is located in an area that has a temperature below 60°C, and that the customer knows where the receiver is for future battery replacement.

COMMISSIONING

1. COMPLETING THE INSTALLATION

THE APPLIANCE MUST NEVER BE OPERATED WITH THE DOOR REMOVED OR GLASS BROKEN.

When the coals and matrices have been arranged as shown, the door(s) must be closed and a good seal achieved using the supplied washer and nut. Finally, the cast knob should be screwed onto the same bolt as the nut. This can then be tightened up with orientation either horizontal or vertical, noting that it is not necessary to “wrench” this knob on tight. Ensure that the Glass rope seal is correct and is forming a good seal around the door in all places.

2. APPLIANCE TESTING

The gas pressure to the appliance must be measured; this should be measured with all gas appliances with the gas meter operating on full. It should be 20mb or 37mb \pm 5%. The flow rate should be checked using the method described in the CORGI Essential Gas Safety book. See Technical Specification section 3.

The above values are on “HIGH” and should be measured whilst all appliances are on full.

3. COMMISSIONING THE STOVE

A spillage test **MUST** be made before the installed fire is left with the customer. Carry out the test by first closing all doors and windows in the room containing the stove.

Ensure the fire is burning at full rate for a minimum of 5 minutes to warm the flue. Using a smoke match, run along the edge of the draught diverter as shown in Fig. 1 below. The smoke should be drawn into the draught divert. The test should be made over the full width of the draught diverter, and the test may be done from either left or right.

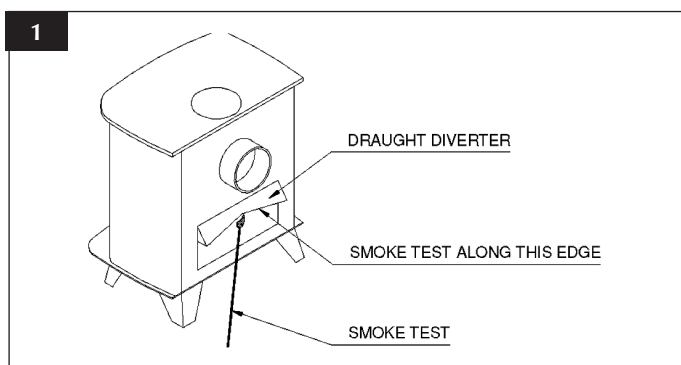

4. POST INSTALLATION CHECKS

Before leaving the appliance connected to the gas supply, the installer is required to visually examine the appliance and flue way to ensure that:

- The seal between the combustion chamber and the room is intact and in good condition.
- The flue has been correctly sealed.
- There is no debris contained within the flue assembly.
- All pipe work must be purged.

PLEASE EXPLAIN TO THE CUSTOMER THE LIGHTING AND EXTINGUISHING PROCEDURES.

SERVICING & FAULT FINDING

ADVICE ON HANDLING & DISPOSAL OF FIRE CERAMICS

The fuel effect matrix and coals in this appliance are made from Refractory Ceramic Fibre (RCF), a material which is commonly used for this application.

Protective clothing is not required when handling these articles, but we recommend you follow normal hygiene rules of not smoking, eating or drinking in the work area and always wash your hands before eating or drinking.

To ensure that the release of RCF fibres are kept to a minimum, during installation and servicing a HEPA filtered vacuum is recommended to remove any dust accumulated in and around the appliance before and after working on it. When servicing the appliance it is recommended that the replaced items are not broken up, but are sealed within heavy duty polythene bags labelled as RCF waste.

RCF waste is classed as stable non reactive hazardous waste and may be disposed of at a licensed landfill site.

Excessive exposure to these materials may cause temporary irritation to the eyes, skin and respiratory tract; wash hands thoroughly after handling the material.

1. SERVICING INSTRUCTIONS

The following outlines only the minimum work that should be performed on an annual basis. This service work, like any other work on the appliance, must only be done by a qualified and competent engineer who is registered with C.O.R.G.I.

- a) Open the door. This is achieved by first unscrewing the cast handle to reveal an M6 nut, unscrew the nut, and door will open.
- b) Remove all coals and matrix from top of burner.
- c) Remove ceramic mat from top of burner and discard.
- d) Remove any debris from the top of the burner using a vacuum cleaner and brush.
- e) Inspect the burner unit.
- f) Perform an ignition check.
- g) Perform a flame failure check
- h) There should be no need to service the burner. If however this is required, then the engineer should check the setting pressure at inlet to burner; the correct pressure is shown on the data information plate.
- i) **Fit new ceramic mat.** Brush off and replace coal arrangement as shown on pages 13-15, replacing any broken or damaged pieces.

- j) Check all seals on door (including glass) and close the Door.
- k) Check the installation for gas leaks.
- l) Check flue for clearance of products of combustion. If any parts need to be replaced use only genuine Yeoman parts, non standard parts will invalidate the guarantee and may be dangerous.

2. TROUBLESHOOTING

A) The gas pilot will not ignite or stay lit?

- i) Ensure the gas is turned on at the appliance and the meter/cylinder.
- ii) Depress the control knob for at least twenty seconds once the pilot is alight to ensure the operation of the safety thermocouple valve.
- iii) Ensure that the pilot injector is not obstructed or blocked and it is free from any dust or dirt.
- iv) Ensure that the thermocouple has not been damaged in transit. This is a very delicate Electro magnetic device.
- v) On propane, the cylinder could be empty.

B) The pilot is not burning or performing correctly?

- i) Ensure the pilot flame is the correct size for the type of gas. The flame should be focused on the thermocouple probe.
- ii) The pilot flame will have been set correctly in the factory.

C) The Main Burner does not seem to be burning correctly?

- i) Ensure adequate gas pressure to the appliance. The pressure can be checked by unscrewing the pressure test nipple and applying a suitable pressure gauge (i.e. a manometer). Ensure adequate volume of gas is being used. Once the fire is burning on maximum, turn off all other gas appliances in the house and calculate the fuel being burned from the gas meter.
- ii) Make sure that the burner is burning correctly. The flame should be even across the top of the burner before any coals are placed on top.

D) Optional Remote Control will not function

- i) Check PP3 battery in the handset is fully charged, if not, change. Check the four AA batteries in the receiver box are fully charged, if not, replace them.

SHORT SPARES LIST

3. SHORT SPARES LIST

Only original Yeoman parts may be used when replacing parts on this appliance.

Exminster Nat Gas & LPG Matrix Set	YM-YA75142
Exminster Nat Gas & LPG Log Set	YM-YA75542
Exminster Ceramic Mat	YM-YG75131
Exminster Mertik Gas Tap Nat Gas	YM-YG75304
Exminster Mertik Gas Tap LPG	YM-YG75305
Exminster Nat Gas injector	YM-YG75077
Exminster LPG Injector	YM-YG14177
Exminster ODS Nat Gas Oxy Pilot Assy	YM-NG9043
Exminster ODS LPG Oxy Pilot Assy	YM-LPG9228
Mertik Ignition Lead	YM-GC0090
Remote Motor Unit	YM-EL0234
4 Sided Twin Door Glass 222x168mm	GL0240
Single Door Glass 384x237x974R	GL0241

SERVICE RECORDS

1ST SERVICE

Date of Service:.....

Next Service Due:.....

Signed:.....

Dealer's Stamp/HETAS Registration Number

2ND SERVICE

Date of Service:.....

Next Service Due:.....

Signed:.....

Dealer's Stamp/HETAS Registration Number

3RD SERVICE

Date of Service:.....

Next Service Due:.....

Signed:.....

Dealer's Stamp/HETAS Registration Number

4TH SERVICE

Date of Service:.....

Next Service Due:.....

Signed:.....

Dealer's Stamp/HETAS Registration Number

5TH SERVICE

Date of Service:.....

Next Service Due:.....

Signed:.....

Dealer's Stamp/HETAS Registration Number

6TH SERVICE

Date of Service:.....

Next Service Due:.....

Signed:.....

Dealer's Stamp/HETAS Registration Number

7TH SERVICE

Date of Service:.....

Next Service Due:.....

Signed:.....

Dealer's Stamp/HETAS Registration Number

8TH SERVICE

Date of Service:.....

Next Due:.....

Signed:.....

Dealer's Stamp/HETAS Registration Number

9TH SERVICE

Date of Service:.....

Next Due:.....

Signed:.....

Dealer's Stamp/HETAS Registration Number

10TH SERVICE

Date of Service:.....

Next Service Due:.....

Signed:.....

Dealer's Stamp/HETAS Registration Number



A division of Stovax Ltd

Falcon Road, Sowton Industrial Estate, Exeter, Devon, England EX2 7LF

Tel: (01392) 474500 Fax: (01392) 219932

E-mail: yeoman@stovax.com www.yeoman-stoves.co.uk